

AVL Warping Wheel Assembly and Usage

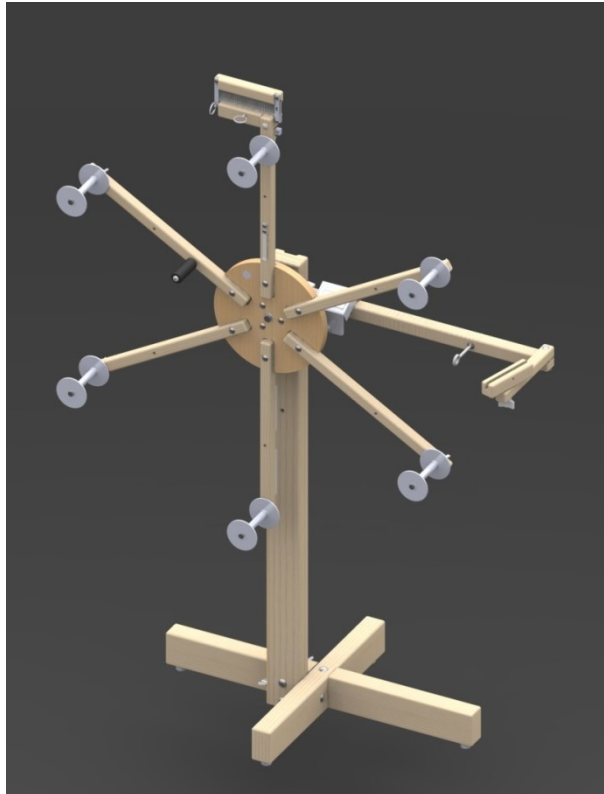

**AVL Looms
2360 Park Avenue
Chico, CA 95928-6785
U.S.A.**

**530 893-4915
530 893-1372 fax
sales@avlusa.com
www.avlusa.com**

**Version 2.1
February 2019**

Assembly..... 2

 Introduction..... 3

 Features 4

 Before You Begin 5

 Assemble the Warping Wheel 7

Instructions..... 25

 Using the Digital Revolution Counter 26

 Setup Warping Wheel..... 26

 Making the First Section..... 27

 Tying Off 30

 Change the battery in the revolution counter 32

ASSEMBLY

INTRODUCTION

About AVL

AVL Looms has been in the business of designing and building some of the world's finest handweaving looms since 1977.

Jim Ahrens had been building and designing looms for a number of years before Jon Violette, the "V" in AVL, approached Ahrens about a partnership in 1977. Violette, an industrial management professional, had discovered Ahrens' work through his sister who ran the Pacific Basin School of Textiles in Berkeley, where Ahrens was a volunteer advisor.

The two men worked together in the Bay Area for three years until Violette moved Ahrens and Violette Looms to Chico, where it officially became known as AVL Looms Inc., and has operated ever since.

In 1982, Violette was instrumental in the development of the first computerized dobby, then called the "Apple Dobby". He retired from active life in the company in 1987. We have christened this new V-Series Loom in recognition of Jon's contribution to handweaving.

Once known for our production looms, AVL has broadened its line considerably and we now offer customers a full spectrum of fine weaving equipment, ranging from our small Home Looms, to our Industrial Dobby Looms, Rug Looms, and Jacquards.

AVL Warping Wheel

The AVL Warping Wheel is a product that will help you do your sectional warping in a fast and efficient way without winding any spools. It will allow you to warp directly from different size cones (the ones that have been sitting in your studio for a while now!) or from just about any other form your warp threads are in. The Wheel adjusts from a circumference of two to three yards, allowing you to put on warps of up to 20 yards.

FEATURES

Adjustable Tension

With a built-in tensioning system, the AVL Warping Wheel will also save you from one time-consuming part of standard sectional warping: threading the tension box. You wind directly from the wheel onto the beam!

And maybe the best part about warping with the AVL Warping Wheel: it will give you the freedom of designing as you go, changing color sequences across the warp without complicated pre-calculations and additional spool winding.

With the built-in tensioning system, you will be able to adjust the tension of your threads going into a particular section on your sectional beam without threading the tension box.

Digital Revolution Counter

You do not have to count your turns any more. The built-in digital counter will do it for you.

Pivoting Raddle

The front raddle will pivot making it easy to adjust the width of the section to fit exactly in the size of the section without rethreading the reed, starting from 5"; (if you just leave the reed straight without pivoting) down to 1"; (the minimum size section on your beam). This feature will give you an easy way to create flat layers in each section of your sectional beam.

Adjustable Height

Our warping wheel is designed with an adjustable height to make it comfortable for all weavers: from people in wheelchairs to weavers over 6' tall.

Sturdy Base

The sturdy base allows you to do the winding as fast or as slow as you feel like without worrying about the wheel tipping over.

BEFORE YOU BEGIN

Warping Wheel Parts Identification

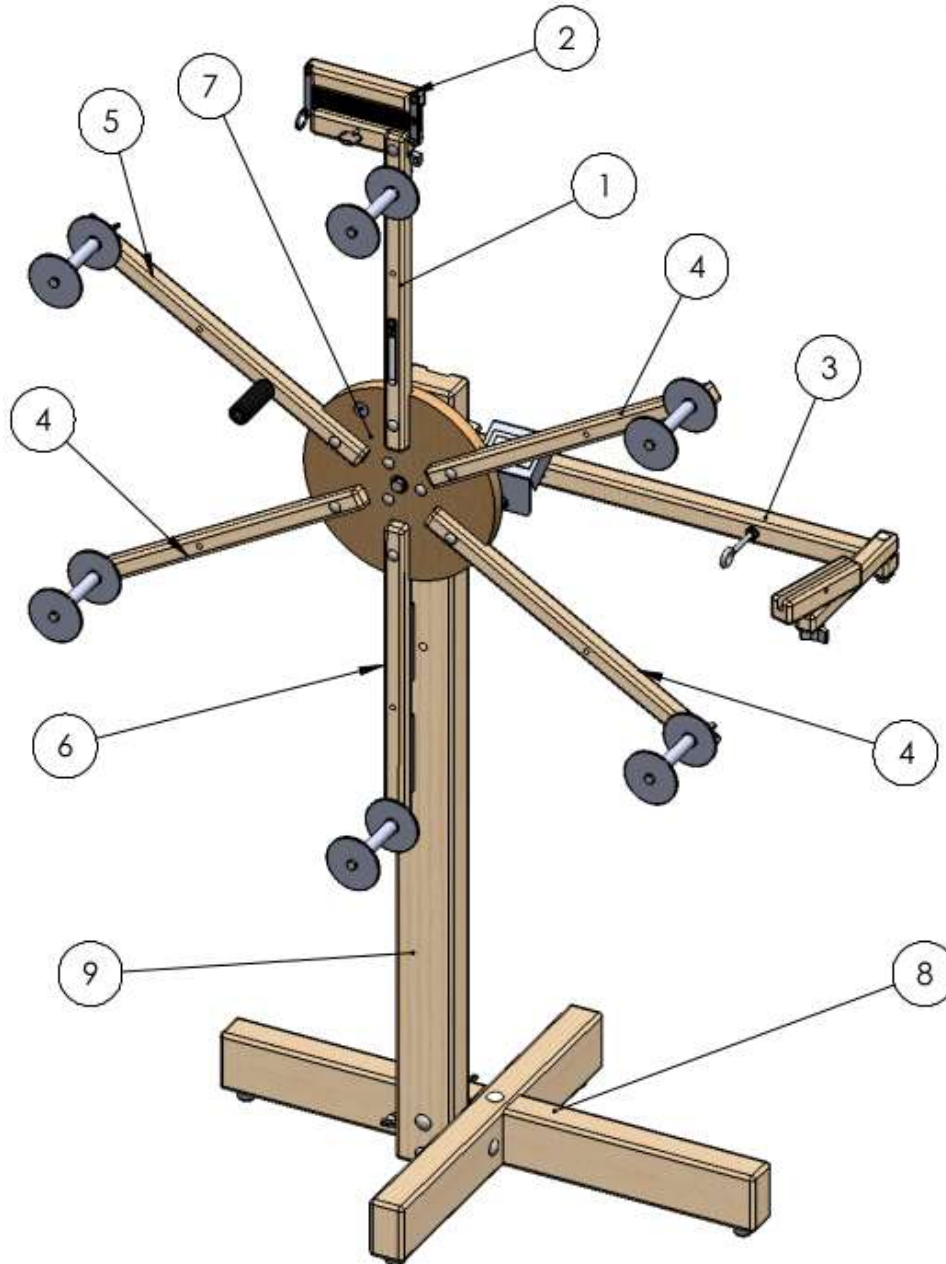

Figure 1 – Warping Wheel Parts

ITEM NO.	PART NUMBER	DESCRIPTION	QTY
1	WW3-SAS2	Riddle Holder Spoke	1
2	WW3-SAS3	Riddle Top Assembly	1

3	WW3-SAS4	Adjustable Raddle Arm Support	1
4	WW3-SAS5	Regular Spoke	3
5	WW3-SAS6	Spoke With Handle	1
6	WW3-SAS8	Spoke with Weights	1
7	WW3-SAS9	Hub & Drum Assembly	1
8	WW3-SAS11	Upper & Lower Base Assembly	1
9	WW3-W9	Vertical	1

Additional Parts

- Seven plastic spools (1 is a spare)
- Digital revolution counter assembly

Hardware Packs (Quantity in parentheses)

#1	3/8-16 x 3-1/2 Carriage Bolt (1), 3/8 Flat Washer (1), 3/8 Lock Washer (1), 3/8-16 Hex Nut
#2	3/8 Flat Washer (3), 3/8-16 x 4 Carriage Bolt (2), 3/8-16 x 5-1/2 Carriage Bolt (1), 3/8-16 Wing Nut (3)
#3	1/4-20 x 2-1/4 Carriage Bolt, 1/4 Flat Washer (1), 1/4-20 Hex Nut (1)
#4	1/4-20 Wing Nut (6), Spool (7), 1/4-20 x 5-1/2 Hex Bolt (6), 1/4 Flat Washer (6)
#5	1/4-20 x 1-3/4 Carriage Bolt (1), 1/4 Flat Washer, 1/4-20 Wing Nut
#6	1/4 Flat Washer (6), 1/4-20 x 1-3/4 Carriage Bolt (6), 1/4-20 Hex Nut (6)

Tools you will need

- Philips Head Screwdriver (electric can be used)
- Hammer
- 7/16" wrench or socket wrench
- 9/16" wrench or socket wrench

ASSEMBLE THE WARPING WHEEL

Base (Use Hardware Pack #1) (Figure 2)

- 1) Place the upper base on top of the lower base noting that the holes for securing the vertical should be to the left on the lower base and closest to you on the upper base.
- 2) To secure the base pieces together, insert the 3/8" x 3-1/2" carriage bolt into the center hole, from the top, and tap into place with a hammer until fully seated.
- 3) Attach a flat washer, lock washer, and finally a hex nut to the end of the bolt and secure with a 9/16" wrench - **firmly**.

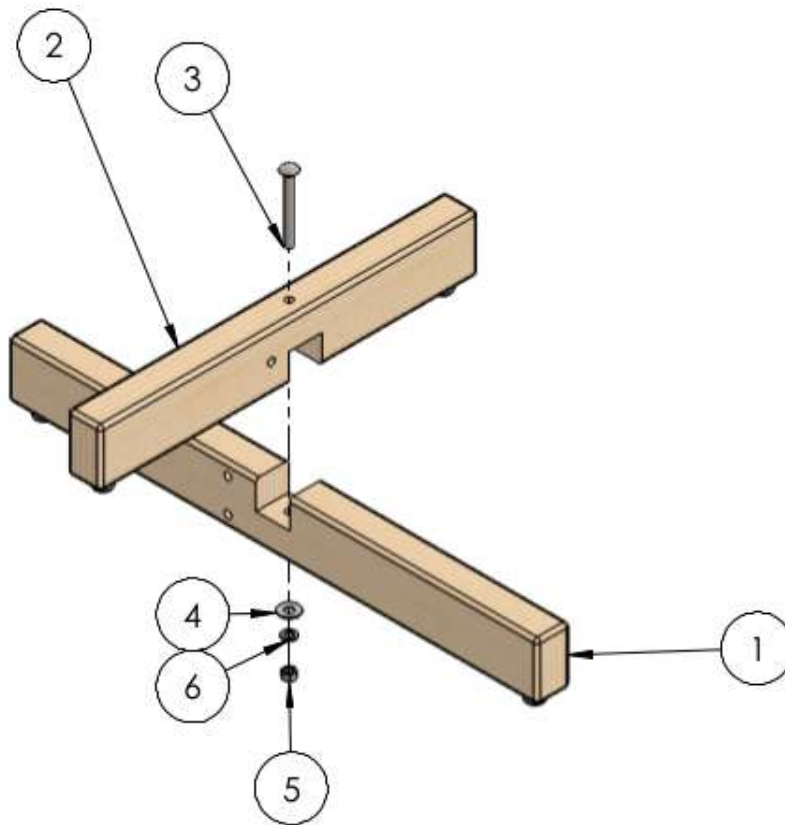

Figure 2a - Warping Wheel Base

ITEM NO.	PART NUMBER	DESCRIPTION	QTY.
1	WW3-W16	Base, Lower	1
2	WW3-W14	Base, Upper	1

3	CB--3/8-16 x 3-1/2"	Carriage Bolt 3/8-16 x 3-1/2	1
4	FW-3/8	Flat Washer 3/8	1
5	HXN-3/8-16	Hex Nut 3/8-16	1
6	LW-3/8	Lock Washer 3/8	1

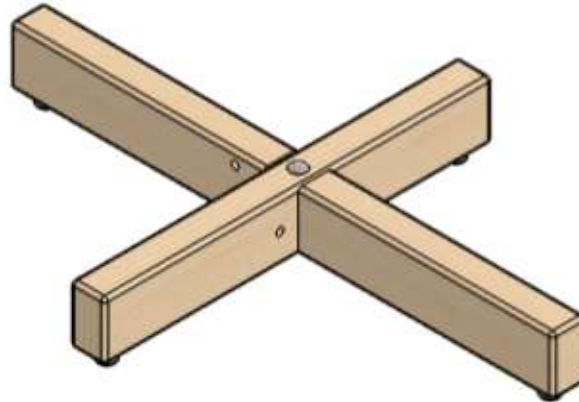
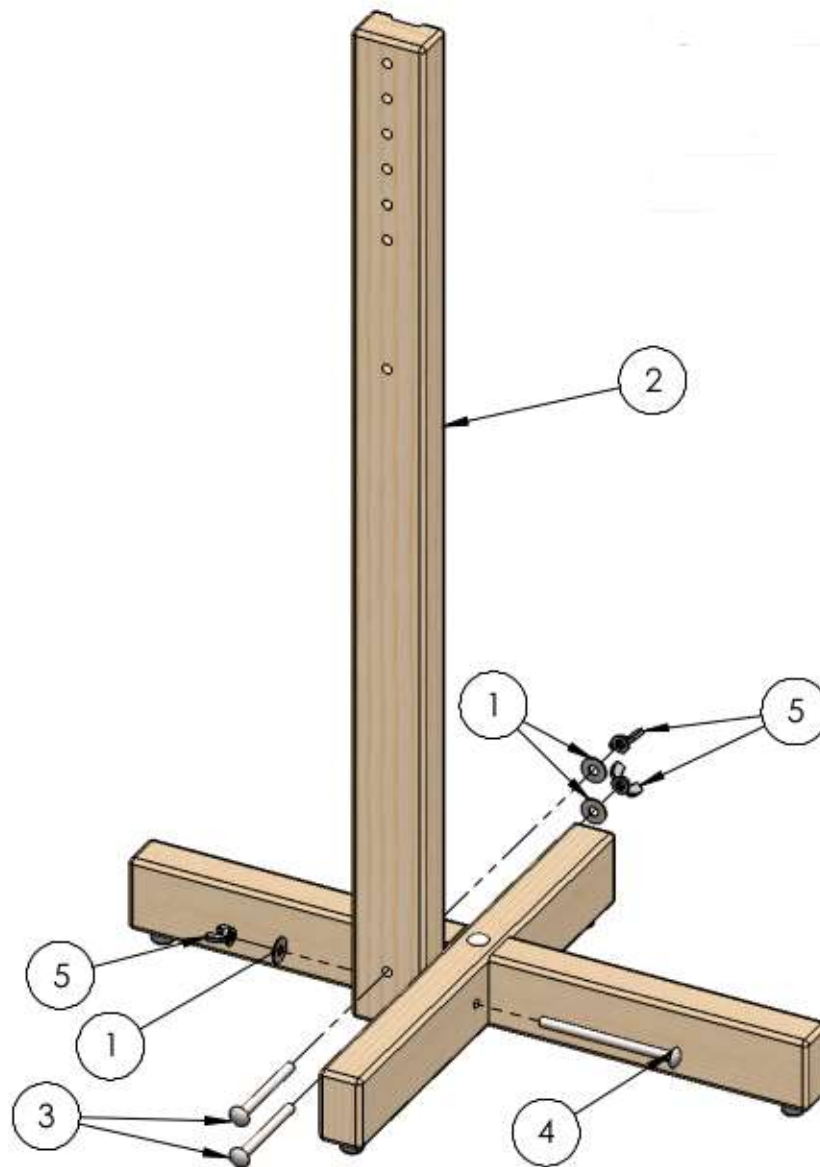

Figure 2b - Warping Wheel Base Complete

Verticals (Use Hardware Pack #2) (Figure 3)

- 1) Bolt the vertical to the front left inside corner of the base using:
 - a. 3/8" x 5-1/2" bolt from right to left
 - b. Two 3/8" x 4" bolts from front to back
- 2) Tap bolts firmly with a hammer until fully seated
- 3) Secure all bolts with one flat washer and one wing nut each

**Figure 3 – Verticals**

ITEM NO.	PART NUMBER	DESCRIPTION	QTY.
1	FW-3/8	Flat Washer	3
2	WW3-W9	Vertical	1
3	CB-3/8-16x4	Carriage Bolt 3/8-16 x 4	2
4	CB-3/8-16x5-1/2"	Carriage Bolt 3/8-16 x 5-1/2	1
5	WGN-3/8-16	3/8-16 Wing Nut	3

Mounting the Drum and Raddle Support w/ Adjustable Raddle Holder(Figures 4 and 5)

Your Warping Wheel comes with seven pre-drilled holes to adjust the height of your Warping Wheel (the lowest hole is intended for use while sitting).

We suggest choosing a hole that is approximately waist high for the primary use.

- 1) Remove the three arm knob, one lock washer, and one flat washer from drum assembly. (Figure 5)
- 2) From the front, insert the center bolt of the drum assembly through the selected hole on the vertical. (Figure 5)
- 3) From the back, attach the raddle support to the back of the vertical (Figure 5)

- 4) Secure the bolt with a flat washer, then a lock washer, and, finally, the three arm knob -- tighten firmly. (Figure 5)

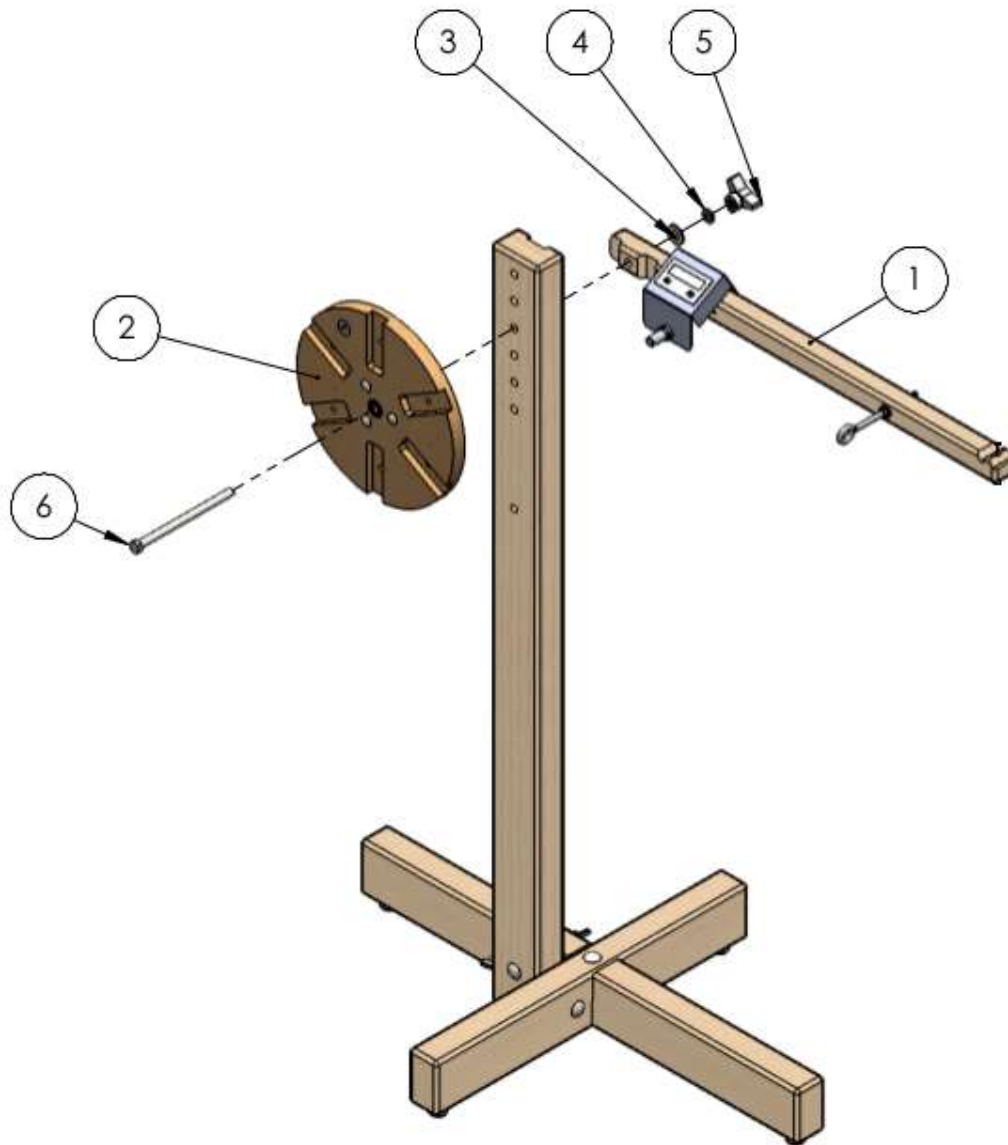

Figure 5 – Drum Support

ITEM NO.	PART NUMBER	DESCRIPTION	QTY.
1	WW3-SAS4	Adjustable Raddle Arm Support	1
2	WW3-SAS9	Hub & Drum Assembly	1
3	FW-3/8	Flat Washer 3/8	1
4	LW-1/4	Lock Washer 1/4	1
5	KNOB-3ARM-3/8-16	Knob, 3-Arm, 3/8-16	1
6	HXB-3/8-16x6	Hex Bolt 3/8-16 x 6	1

- 5) Using the 1/4-20 x 2-1/4" carriage bolt (Hardware Pack #3), attach the raddle mount/adjustable raddle holder assembly to the raddle support. Secure with the flat washer and wing nut. (Figure 4)

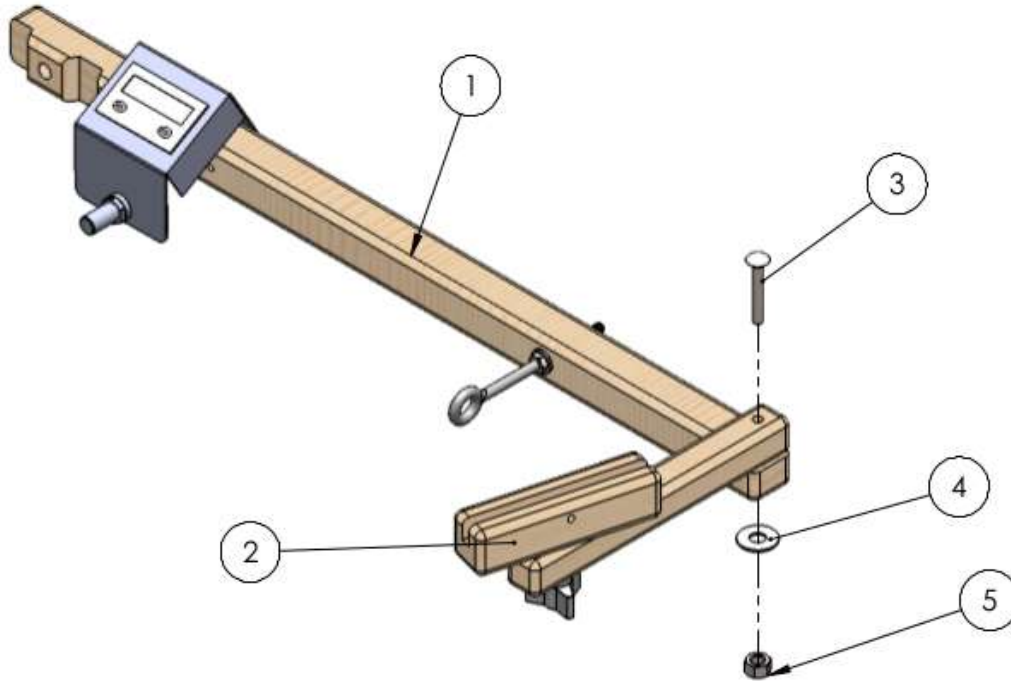

Figure 4 – Raddle Assembly

ITEM NO.	PART NUMBER	DESCRIPTION	QTY.
1	WW3-SAS4	Adjustable Raddle Arm Support	1
2	ACC-WW2-SAS6	Holder, Adjustable Reed	1
3	CB-1/4-20x2-1/4	Carriage Bolt 1/4-20 x 2-1/4	1
4	FW-1/4	Flat Washer 1/4	1
5	HXN-1/4-20	Hex Nut 1/4-20	1

Routing the Tension Tie-Up

- 1) The tension tie-up assembly is already secured to the raddle support.
- 2) Wrap the black tension cord from the back of the warping wheel. Come from the arm, over the top of the drum, wrap two full rotations clockwise, and then back to the arm underneath the drum.



Tension Tie-up

- 3) Take the end with the quick link and attach the quick link to the eyebolt under the white cord. Close the threaded side of the quick link.



Close up of Tension Tie-up

Spokes (Use Hardware Pack #6)(Figures 11, 12, 13)

Tip:

Make sure the nuts and washers are secured on the back of the wheel.

- 1) Take the spoke with the cord catch assembly and mount it in the twelve o'clock position on the drum assembly so that the AVL emblem is to the left of the spoke (Figure 11)

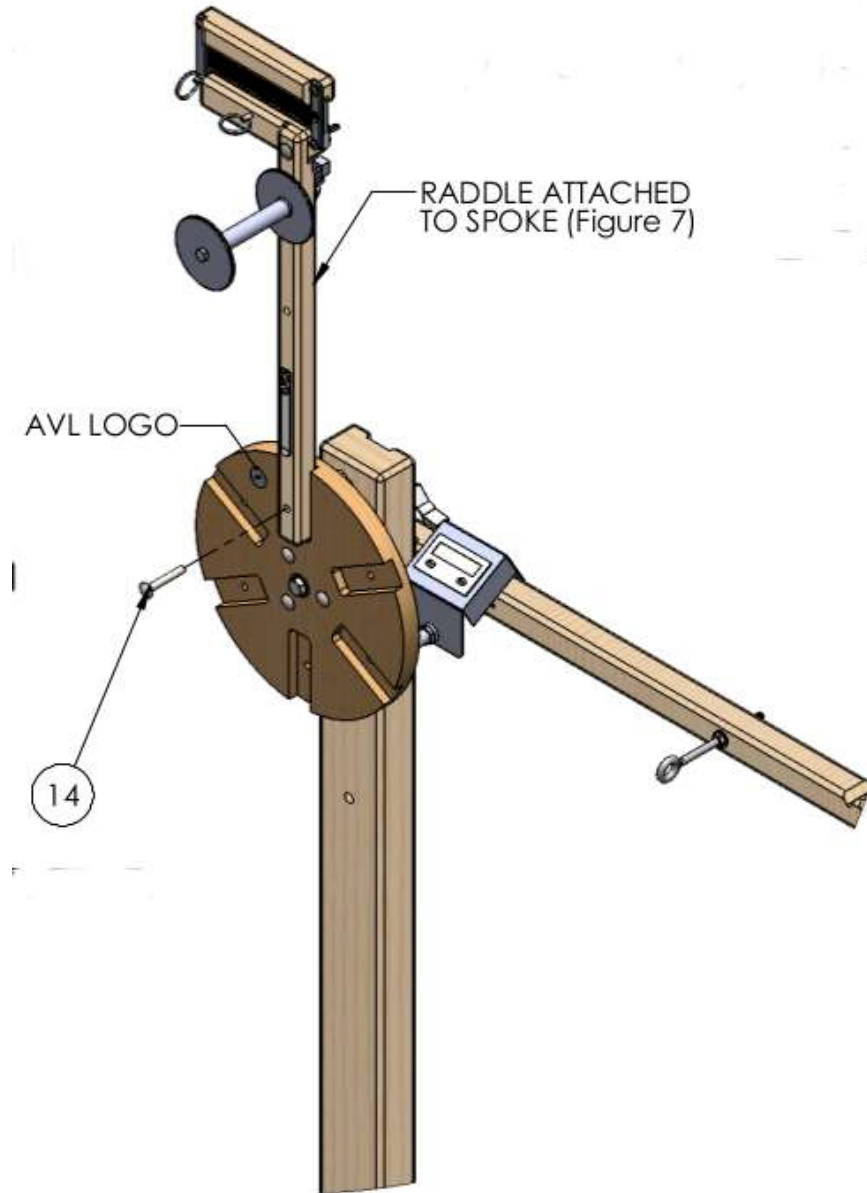

Figure 11a – Cord Catch Spoke

ITEM NO.	PART NUMBER	DESCRIPTION	QTY.
14	CB 1/4-20x1-3/4	Carriage Bolt 1/4-20 x 1-3/4	1

- 2) Bolt it in place from the front to the back and secure it with a flat washer and hex nut. Tighten with a 7/16" wrench.(Figure 11)

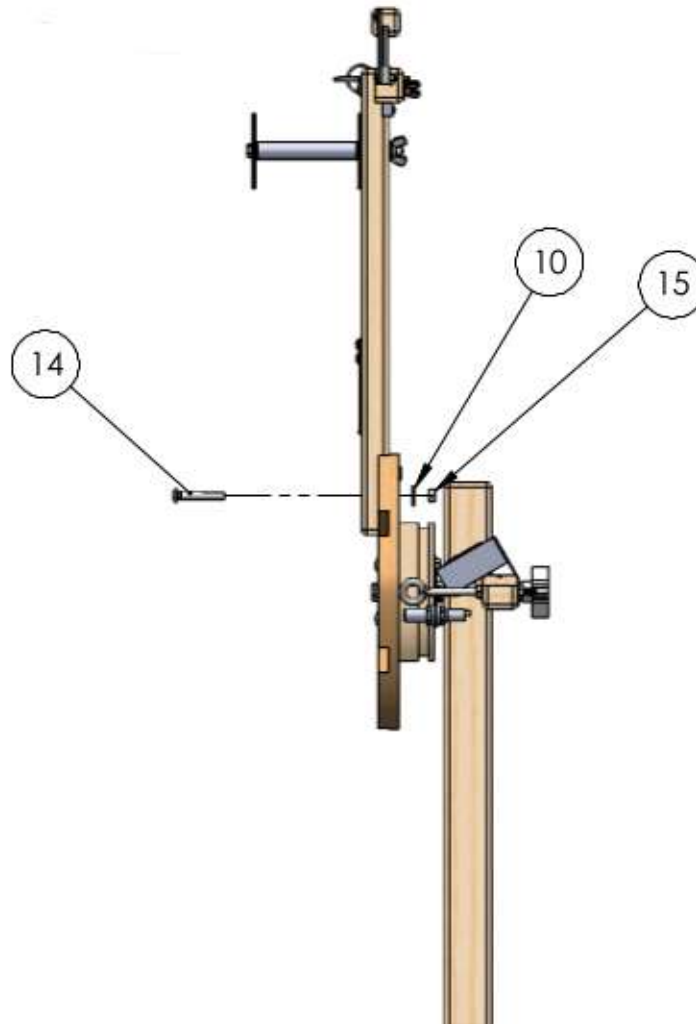

Figure 11b – Spoke from right side

ITEM NO.	PART NUMBER	DESCRIPTION	QTY.
10	FW-1/4	Flat Washer 1/4	1
14	CB 1/4-20x1-3/4	Carriage Bolt 1/4-20 x 1-3/4	1
15	HXN-1/4-20	Hex Nut 1/4-20	1

- 3) Then take the spoke with the weight on it and mount it in the six o'clock location on the drum assembly, with the weights facing toward the stand (vertical). (Figure 12)
- 4) Take the spoke with the Handle on it and mount it in the location shown in Figure 12.

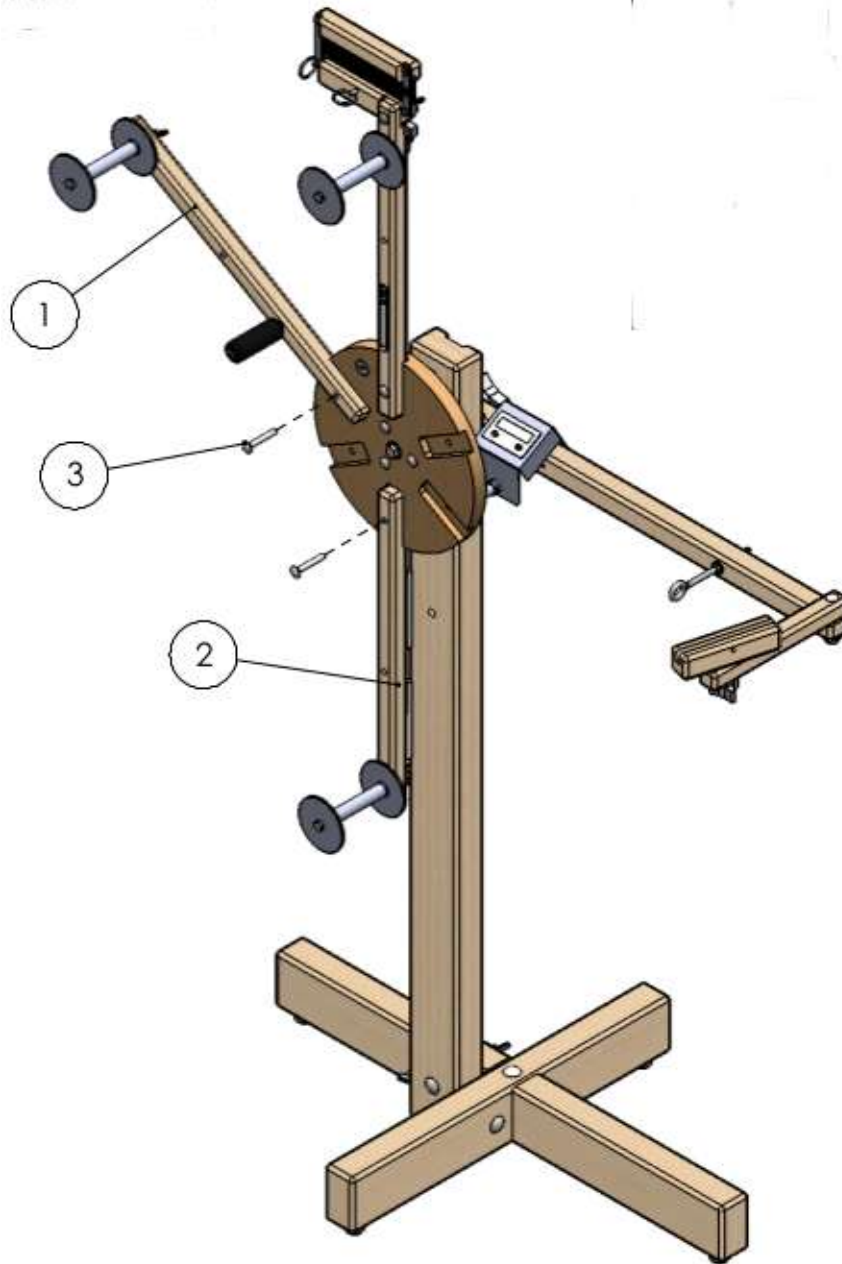

Figure 12 – Spokes with weight and handle

ITEM NO.	PART NUMBER	DESCRIPTION	QTY.
1	WW3-SAS6	Spoke With Handle	1
2	WW3-SAS8	Spoke with Weights	1
3	CB 1/4-20x1-3/4	Carriage Bolt 1/4-20 x 1-3/4	2
4	FW-1/4	Flat Washer 1/4	2
5	HXN-1/4-20 x	Hex Nut 1/4 -20	2

5) Mount the remaining 3 spokes on the drum assembly. (Figure 13)

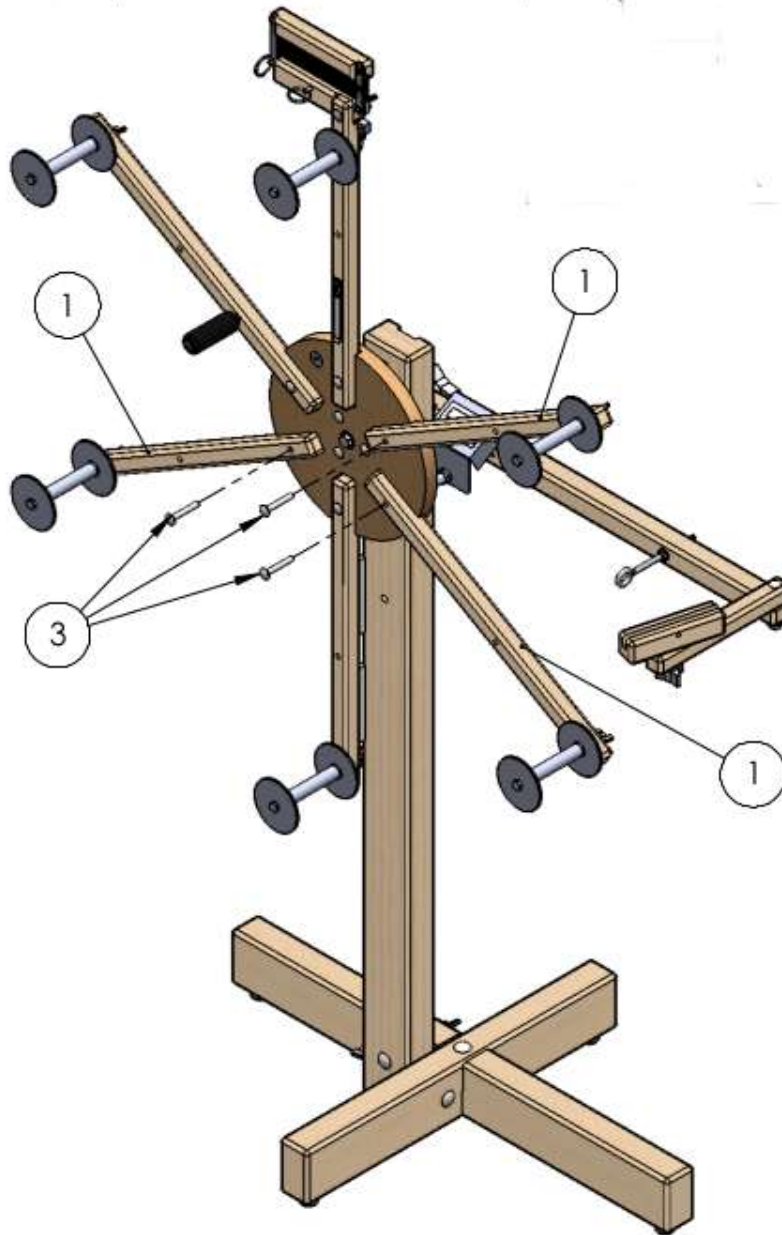

Figure 13 – Warping Wheel with Spokes

ITEM NO.	PART NUMBER	DESCRIPTION	QTY.
1	WW3-SAS5	Regular Spoke	3
2	FW-1/4	Flat Washer 1/4	3
3	CB 1/4-20x1-3/4	Carriage Bolt 1/4-20 x 1-3/4	3
4	HXN-1/4-20	Hex Nut 1/4-20	3

Spools (Use Hardware Pack #4 & Spool Bag) (Figures 6, 8, 9, 10)

- 1) Bolt the spool to the spoke. Secure spool to the spoke with one washer and one wing nut in the back

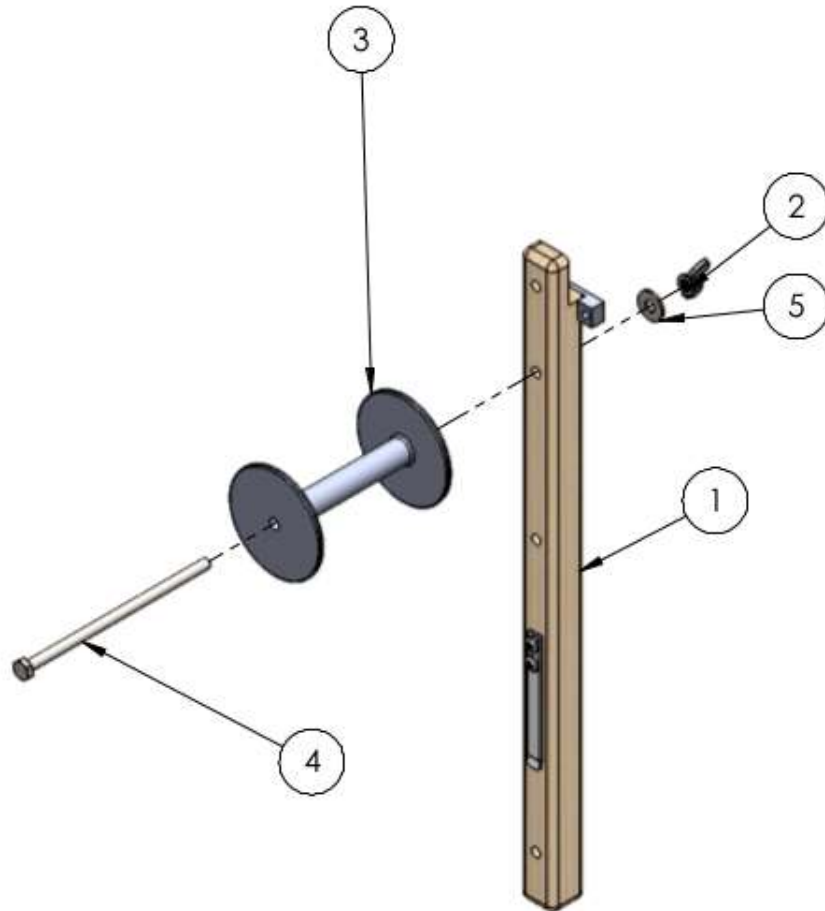

Figure 6 – Attach Spool to Spoke with clip

ITEM NO.	PART NUMBER	DESCRIPTION	QTY.
1	WW3-W7	Spoke w/ Clip	1
2	WGN 1/4-20	Wing Nut, 1/4-20	2
3	SR-SPOOL-001	Spool, 4 inch	1
4	HXB 1/4-20x5-1/2	Hex Bolt 1/4-20 x 5-1/2	1
5	FW-1/4	Flat Washer 1/4	1

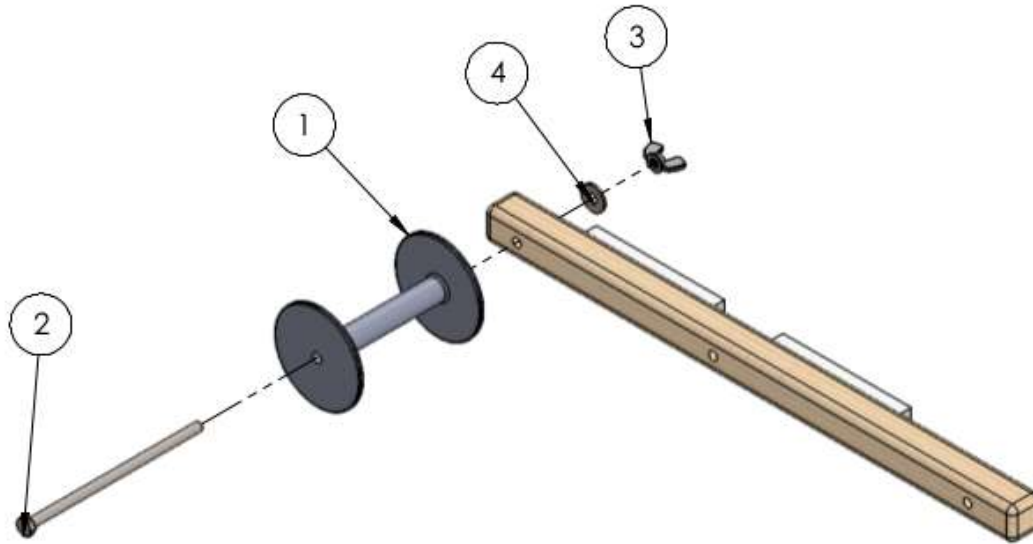

Figure 8a – Attach Spool to Weighted Spoke

ITEM NO.	PART NUMBER	DESCRIPTION	QTY.
1	SR-SPOOL-001	Spool, 4 inch	1
2	HXB 1/4-20x5-1/2	Hex Bolt 1/4-20 x 5-1/2	1
3	WGN 1/4-20	Wing Nut, 1/4-20	1
4	FW-1/4	Flat Washer 1/4	1

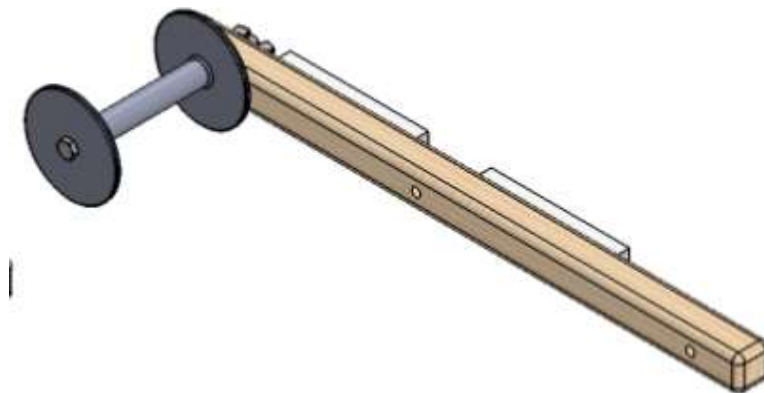

Figure 8b – Spool attached to Weighted Spoke

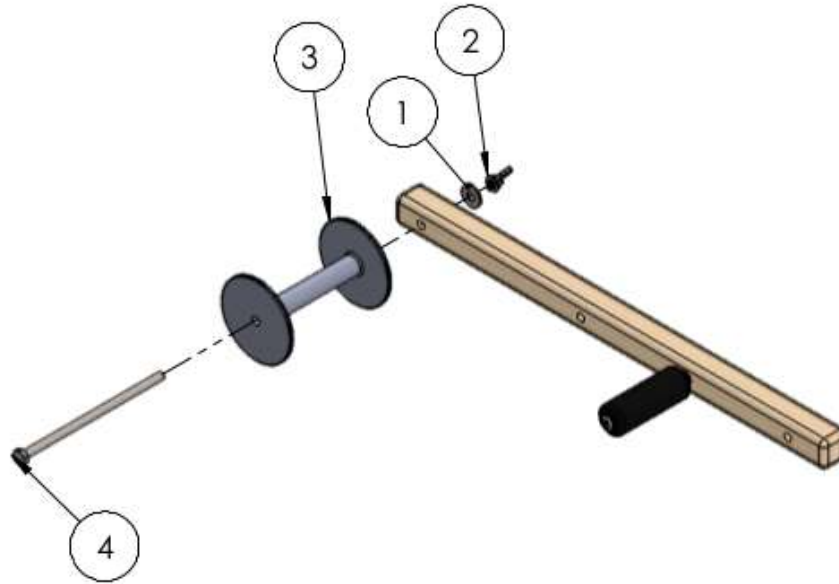

Figure 9a – Attach Spool to Spoke with handle

ITEM NO.	PART NUMBER	DESCRIPTION	QTY.
1	FW-1/4	Regular Flat Washer 1/4	2
2	WGN 1/4-20	Wing Nut, 1/4-20	1
3	SR-SPOOL-001	Spool, 4 inch	1
4	HXB 1/4-20x5-1/2	Hex Bolt 1/4-20 x 5-1/2	1

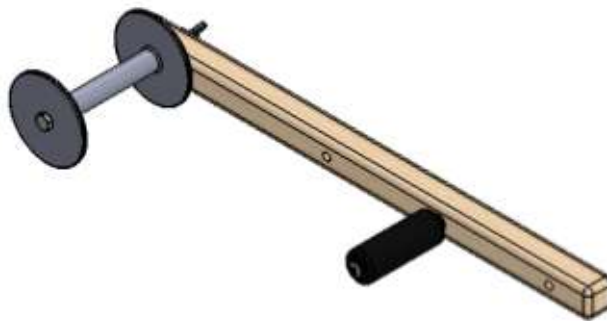

Figure 9b – Spool attached to spoke with handle

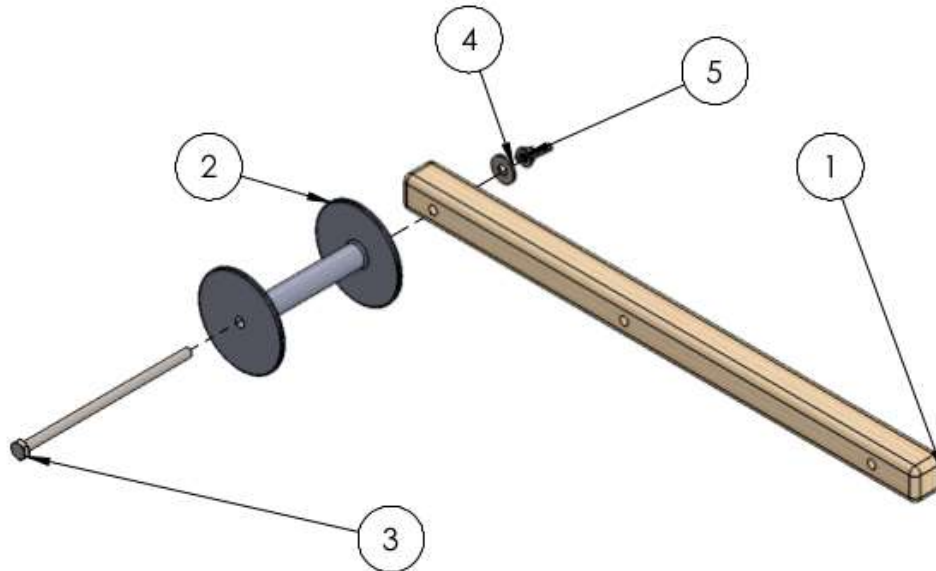

Figure 10a – Attach Spool to Spoke

ITEM NO.	PART NUMBER	DESCRIPTION	QTY.
1	WW3-W11	Spoke, Regular	1
2	SR-SPOOL-001	Spool, 4 inch	1
3	HXB 1/4-20x5-1/2	Hex Bolt 1/4-20 x 5-1/2	1
4	FW-1/4	Regular Flat Washer 1/4	1
5	WGN 1/4-20	Wing Nut, 1/4-20	1

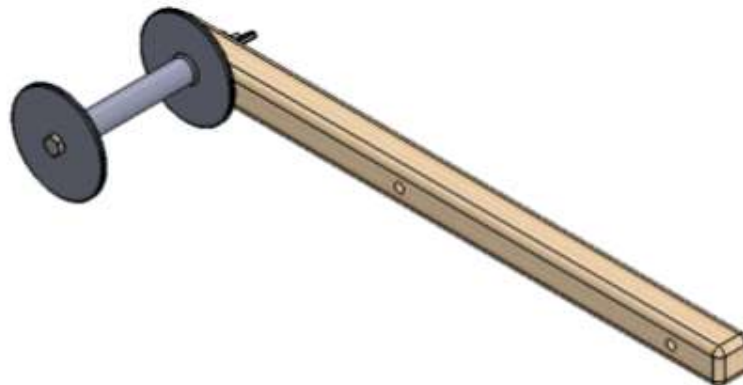

Figure 10b – Spool attached to Spoke

Raddle (Figure 7)

- 1) Using the 1/4" x 1-3/4" carriage bolt(Hardware Pack #5), secure with the flat washer and wing nut. Mount the stationary raddle holder to the spoke with the cord catch assembly.

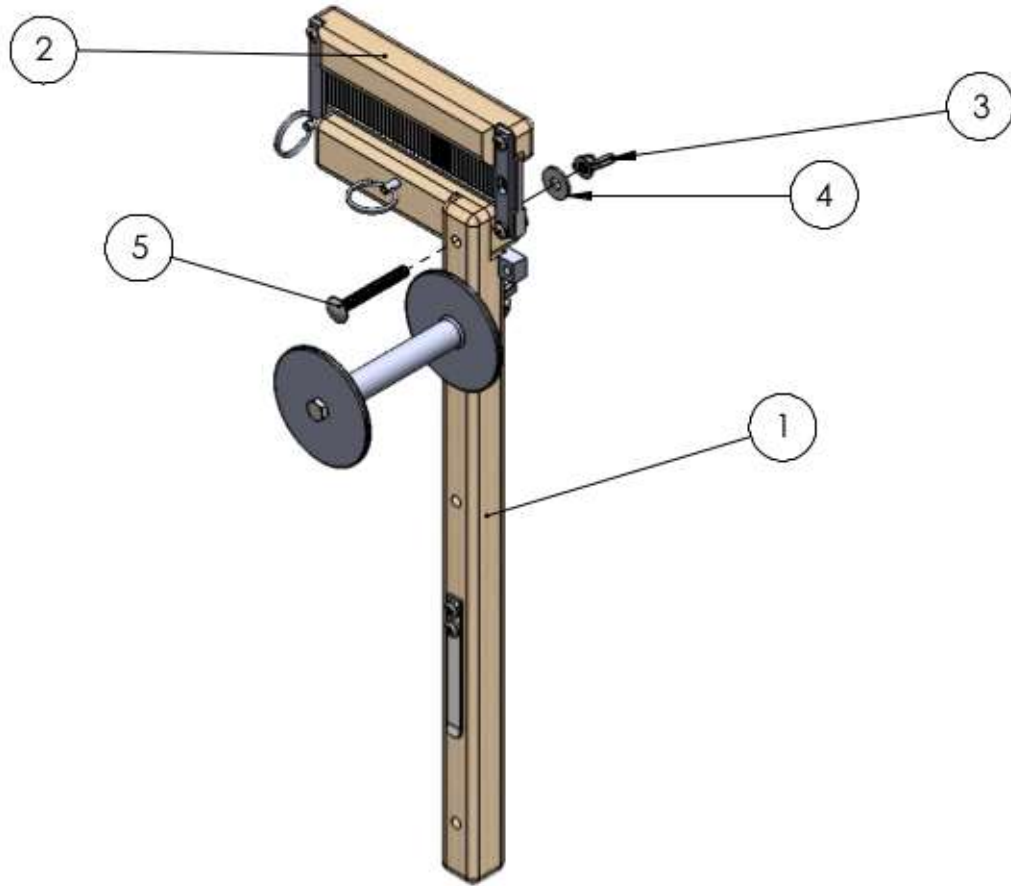

Figure 7 – Rattle Holder

ITEM NO.	PART NUMBER	DESCRIPTION	QTY.
1	WW3-SAS2	Rattle Holder Spoke	1
2	WW3-SAS3	Rattle Top Assembly	1
3	WGN 1/4-20	Wing Nut, 1/4-20	1
4	FW-1/4	Flat Washer 1/4	1
5	CB-1/4-20x1-3/4	Carriage Bolt 1/4-20 x 1-3/4	1

Congratulations, you're finished with assembly. Happy warping!

INSTRUCTIONS

USING THE DIGITAL REVOLUTION COUNTER

The Digital Revolution Counter has a "Pause" and "Reset" button. The counter does not turn off and stays on.

- 1) The "Pause" button will stop the revolution counter. Make sure the button is not depressed when spinning the warping wheel.
- 2) The "Reset" button will reset the number of revolutions the Warping Wheel has made.

SETUP WARPING WHEEL

- 1) Adjust height so position of mini-raddle is just below eye level.
- 2) Adjust the wind-off tension with toggle and cord. Tie cord to prevent slipping.

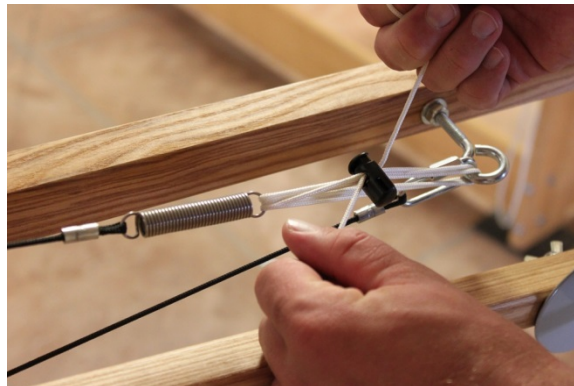

Figure 1 - Adjust Wind-off Tension

- 3) Adjust Warp Length using different spool placement by moving the spools on the arms.

Arms or Spools in outer position	Arms or Spools in inner position	Circumference (+ or - 3 inches)
6	0	3 yards
5	1	2 yards, 30"
4	2	2 yards, 25"
3	3	2 yards, 20"
2	4	2 yards, 15"
1	5	2 yards, 10"

- 4) Reset the Revolution Counter to Zero

- 5) Setup Cones with the Cone Caddy

MAKING THE FIRST SECTION

- 1) Open and secure the raddle top using the removable pin.
- 2) Slide the thread(s) under the metal catch clip, tails facing to the left. Tails should be about 5 inches long.

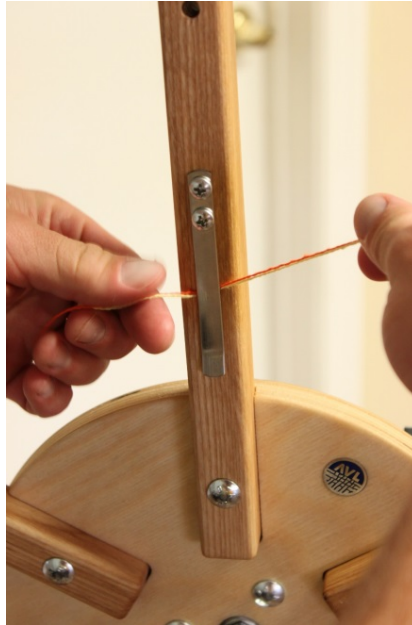

Figure 2 - Catch Thread Ends

- 3) Bring the thread(s) up and over the left side of the top spool so that you are ready to wind the Warping Wheel in a counter clockwise motion.

Tip:

Use your left hand to wind the wheel while your right hand holds the threads.



Figure 3 - Wind Counter Clockwise

- 4) After you have wound one length bring the thread(s) around the back of the raddle and through a dent (working from right to left).

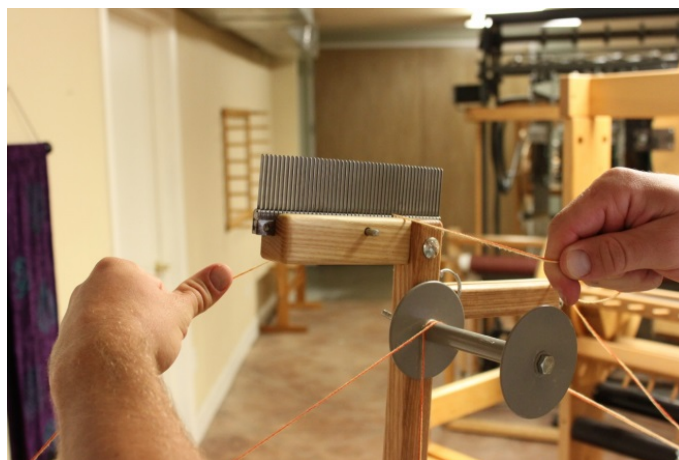

Figure 4 - Bring Thread Through Raddle

- 5) Bring thread(s) down over the end you just wound and secure in the silver clip (swooping under from left to right).

Tip:

Start a few dents from the right and don't skip any dents once you get started! You can put more than one end per dent.

- 6) The width of your section should be equal to or slightly larger than then section on your warp beam. Not smaller! See photo for example.



Figure 5 – Width of sections

TYING OFF

- 1) Put the raddle top back on. Cut the bout threads just to the left of the clip and under the threads going over the wheel.
- 2) Hold onto the threads securely at the raddle (so they don't slip through). Below, wrap the cut threads around the clip.



Figure 6 - Hold Threads at Raddle

- 3) With the raddle top secure, remove the pin from the raddle holder while holding onto the threads.



Figure 7 - Remove Raddle from Top Position

- 4) Bring the raddle down to the winding-on position and secure with the pin. Tie a knot in the thread past the raddle so it won't slip through.



Figure 8 - Place Raddle in Lower Position

- 5) Take the extension cord from your beam. Create a larks head loop at its end and loop it around the knotted end of your warp section.

Tip:

Each extension cord from your beam should be of equal length.



Figure 9 - Place Extension Cord Around Thread Bundle

- 6) Before the last part of the threads pass through the raddle, tape the threads on the loom-side of the raddle in their sequence using masking tape. This will help you keep the threads in order when you thread the harness.
- 7) As you wind on, pivot the raddle to adjust the width of the section to fit exactly in-between the pegs on your sectional beam.



Figure 10 - Pivot Raddle

Tip:

Once you set the tension of your first section (using the toggle adjustment) do not change throughout the warp.

CHANGE THE BATTERY IN THE REVOLUTION COUNTER

Tools needed

- Philips Head Screwdriver (ideally with a long, narrow shaft)
- Flat Head Screwdriver or narrow flat object
- AA Battery

Tip:

Take note of the distance from the tip of the sensor to the magnet. It should be around 1/8th of an inch.

- 1) On the bottom of the counter there are two screws, holding the counter to the Counter Bracket. Unscrew these two screws.



Figure 11 - Bracket screws

- 2) Now unscrew the 2 black colored nuts on the orange sensor. Carefully remove the sensor and digital counter from the counter bracket.

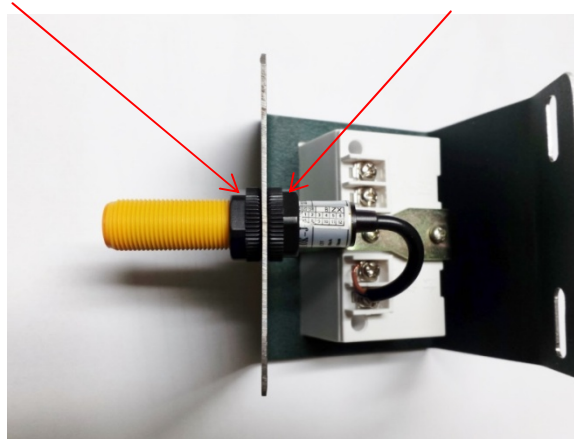

Figure 12 - Orange Sensor

- 3) Unscrew the screws in the two deep holes shown below.

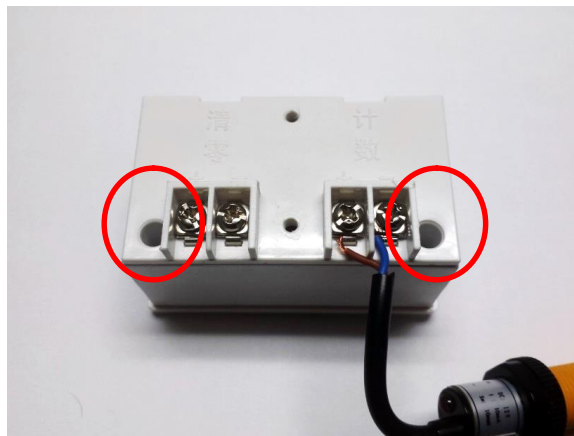

Figure 13 - Screws

- 4) Insert a flat head screwdriver (or other flat object) into the slots shown to open the digital counter. Press until the cover releases.

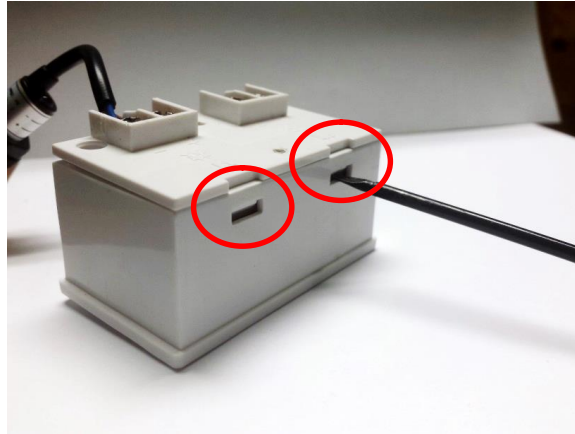

Figure 14 - Slots

- 5) Now remove the AA battery and replace with new battery. Take note of the battery orientation.

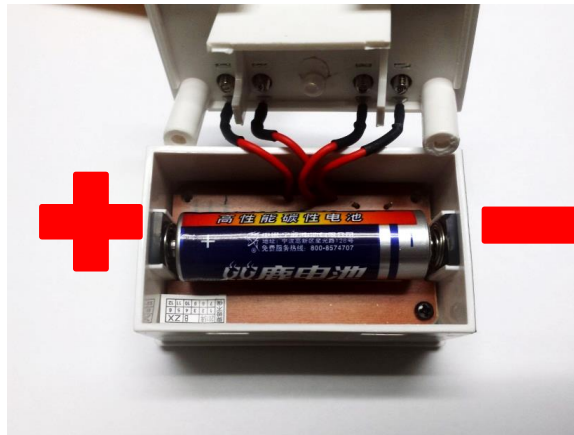

Figure 15 - Battery

- 6) Reverse steps to reassemble the digital counter into the counter bracket. Some adjustment of the black colored nuts may be needed so that the magnet is the correct distance from the orange sensor.